

**TECHNICAL DATA SHEET**

# MG SERIES

## INCLINED LIQUID COLUMN MANOMETERS

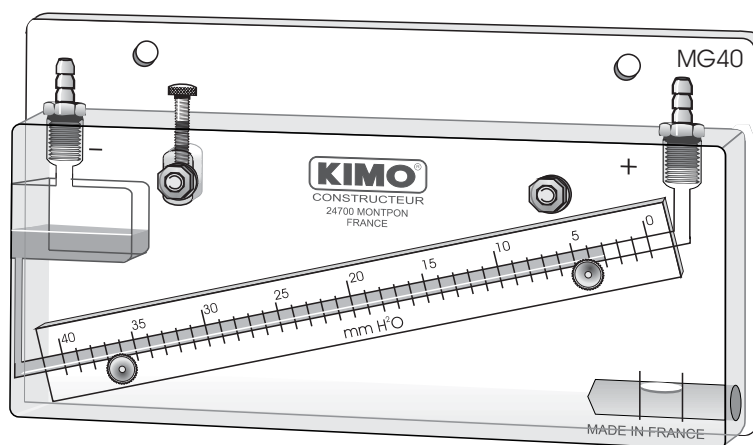

The MG range of inclined liquid column manometers, developed and manufactured by KIMO, measure slight variations in pressure, depression or differential pressure of air or gas. They are for use in the following applications : treatment of air, ventilation, air conditioning, heating, dust elimination...

- Zero adjustment by moving the slide strip
- Safety reservoir enabling momentaneous overshooting of the scale
- Integrated spirit level for adjusting horizontality
- Comes with a white PVC support, 2 screws and 2 rawlplugs, two 487 connectors and a bottle of AWS 10 liquid.

**MEASUREMENT RANGE**

REFERENCE	MEASUREMENT RANGE			SENSITIVITY SCALE		RESOLUTION
	mm CE	Pascal	In WG	for 1 mm CE or 10 Pa	for 0,1 in WG	
<b>MG 20</b>	0 - 20	0 - 200	0 - 0,8	8 mm	20,32 mm	0.5 mm CE or 5 Pa or 0.01 In WG
<b>MG 40</b>	0 - 40	0 - 400	0 - 1,6	4 mm	10,16 mm	1 mm CE or 10 Pa or 0.02 In WG
<b>MG 50</b>	0 - 50	0 - 500	0 - 2	3 mm	7,62 mm	1 mm CE or 10 Pa or 0.02 In WG
<b>MG 60</b>	0 - 60	0 - 600	0 - 2,4	3 mm	7,62 mm	1 mm CE or 10 Pa or 0.02 In WG
<b>MG 80</b>	0 - 80	0 - 800	0 - 3,2	2,5 mm	6,35 mm	1 mm CE or 10 Pa or 0.02 In WG
<b>MG 100</b>	0 - 100	0 - 1000	0 - 4	2,5 mm	6,35 mm	1 mm CE or 10 Pa or 0.02 In WG

Also exists in DaPa.

## CHARACTERISTICS

- Recommended range of use : +5 to 30°C.
- Possible range of use : -30 to 60°C.
- Maximum static pressure : 6 bars.
- Manometer body : transparent 15 mm thick Altuglas
- Liquid column : entirely bored in the solid block, Ø 4mm.
- Graduated slide strip : transparent Altuglas. Cross-section 20x2mm.
- Zero adjustment by moving the graduated slide strip, travel 12 mm. Fixed in place via milled, nickel-plated brass screw.
- Horizontal positioning via integrated spirit level and milled, nickel-plated brass adjusting screw, vertical travel 12 mm.
- Manometric liquid : AWS 10 red oil, density 0.87 to 15°C.
- Reservoir capacity : 20 ml.
- Connection : Ø 5x8 mm semi-rigid crystal tube, on Ø 6.2 mm ribbed, nickel-plated brass connectors, 1/8 gas thread.
- Wall-mounted with or without white PVC support.

## DIMENSIONS

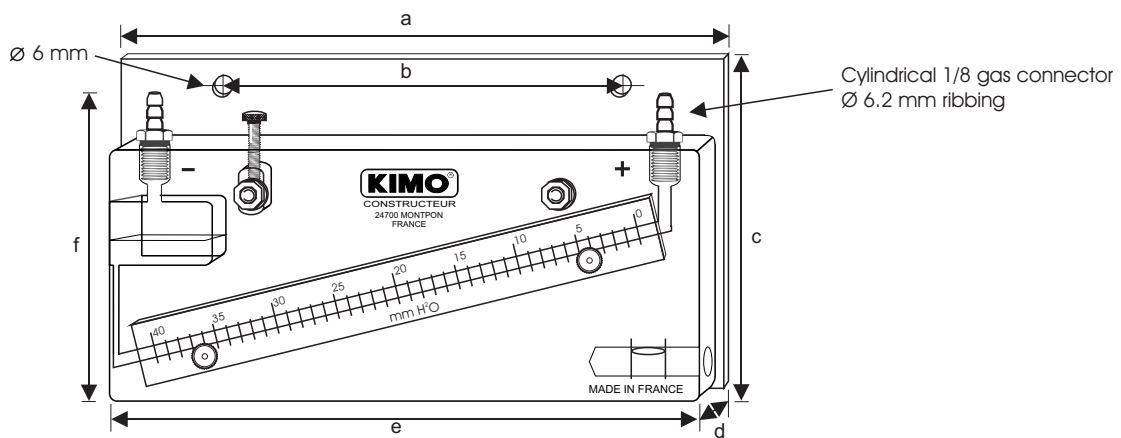

REFERENCE	a	b	c	d	e	f	Weight
<b>MG 20</b>	196 mm	128 mm	80 mm	25 mm	192 mm	55 mm	320 g
<b>MG 40</b>	192 mm	124 mm	105 mm	25 mm	188 mm	80 mm	420 g
<b>MG 50</b>	178 mm	110 mm	117 mm	25 mm	174 mm	109 mm	420 g
<b>MG 60</b>	206 mm	138 mm	129 mm	25 mm	202 mm	104 mm	560 g
<b>MG 80</b>	219 mm	151 mm	154 mm	25 mm	215 mm	129 mm	660 g
<b>MG 100</b>	265 mm	197 mm	175 mm	25 mm	269 mm	150 mm	920 g

## MOUNTING

Mount the manometer on a wall or a vertical partition wall with two maximum Ø 5 screws. Set horizontality by using the integrated level and the milled adjusting screw. Unscrew the connector on the reservoir and slowly pour the manometric liquid to zero point on the graduation. Remount the connector without overtightening. Connect the manometer with the Ø 5x8 mm crystal tube to the pressure or depression source to be checked.

### NOTE :

- For a pressure measurement : connect the crystal tube to the right-hand connector (+).
- For a depression measurement : connect the crystal tube to the left-hand connector (-).
- For a differential pressure measurement : connect the highest pressure to the right-hand connector (+) and the lowest pressure to the left-hand connector (-).

**MAINTENANCE :** MG manometers require no special maintenance other than simply changing the reading liquid once a year.

[www.kimo.fr](http://www.kimo.fr)

### EXPORT DEPARTMENT

BP 48. Bld de Beaubourg - Emerainville  
F-77312 MARNE LA VALLEE CEDEX 2 - FRANCE  
Tel : 33. 1. 60. 06. 69. 25  
Fax : 33. 1. 60. 06. 69. 29  
e-mail : kimo.export@kimo.fr



Distributed by :